

# WIRING DIAGRAMS



**BUSES 8200-8349**

## ALPHABETICAL INDEX

NAME	DRAWING NUMBER	PAGE
<u>BUZZER &amp; HORN CIRCUITS</u>	<u>SK-E-82558-A</u>	<u>1</u>
<u>CHARGING CIRCUIT</u>	<u>-B</u>	<u>2</u>
<u>DOOR CONTROL CIRCUITS</u>	<u>-C</u>	<u>3</u>
<u>HEAT &amp; VENT CIRCUITS</u>	<u>-D</u>	<u>4</u>
<u>HORN &amp; BUZZER CIRCUITS</u>	<u>-A</u>	<u>1</u>
<u>IGNITION CIRCUIT</u>	<u>-E</u>	<u>5</u>
<u>LIGHT CIRCUITS</u>	<u>-F</u>	<u>6</u>
<u>THROTTLE DIP CIRCUIT</u>	<u>-G</u>	<u>7</u>
<u>SHIFT CIRCUIT</u>	<u>-H</u>	<u>8</u>
<u>STARTING CIRCUIT</u>	<u>-I</u>	<u>9</u>
<u>VENT &amp; HEAT CIRCUITS</u>	<u>-D</u>	<u>4</u>
<u>LAMP DATA</u>	<u>-J</u>	<u>10</u>

8200-8349

REVISED 9-30-63

REVISED 10-31-58

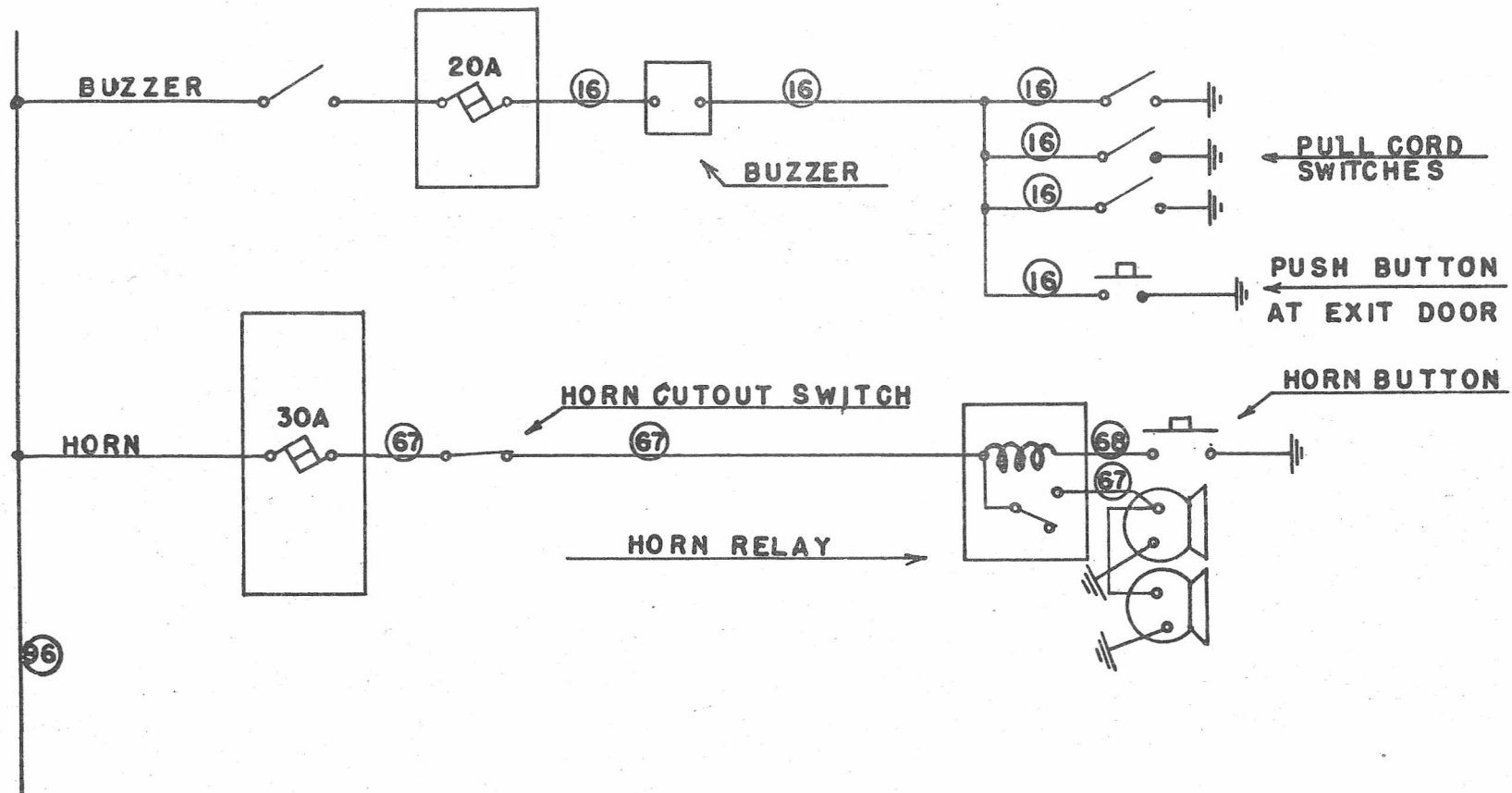

**BUZZER & HORN CIRCUITS  
8200-8349**

CHICAGO TRANSIT AUTHORITY  
GENERAL SUPERINTENDENT OF ENGINEERING  
EQUIPMENT ENGINEER'S OFFICE

**SK-E-82558-A**

REV. 10-31-58

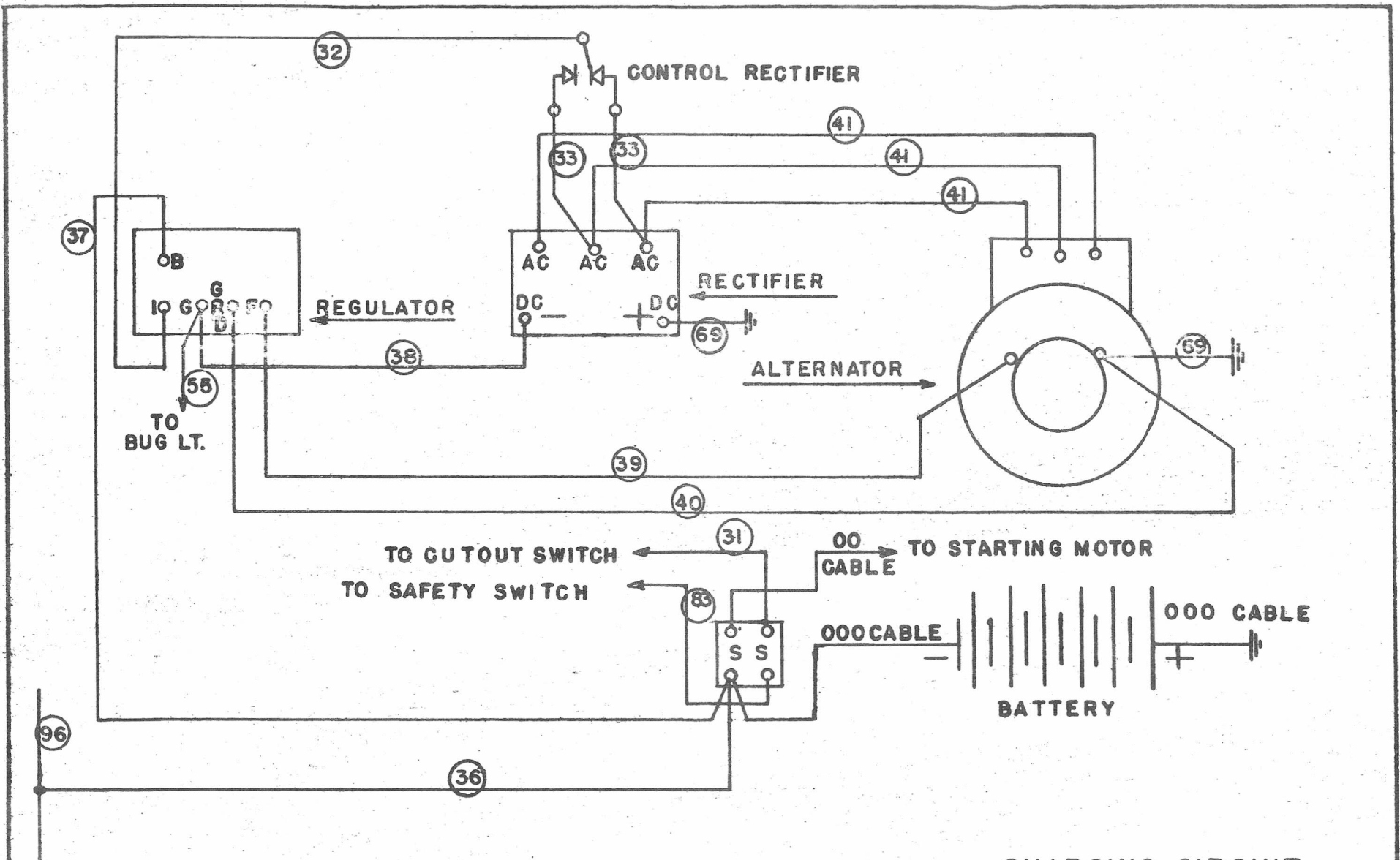

**CHARGING CIRCUIT  
8200-8349**

CHICAGO TRANSIT AUTHORITY  
GENERAL SUPERINTENDENT OF ENGINEERING  
EQUIPMENT ENGINEER'S OFFICE

Rev. 9-17-58

SK-E-82558-B

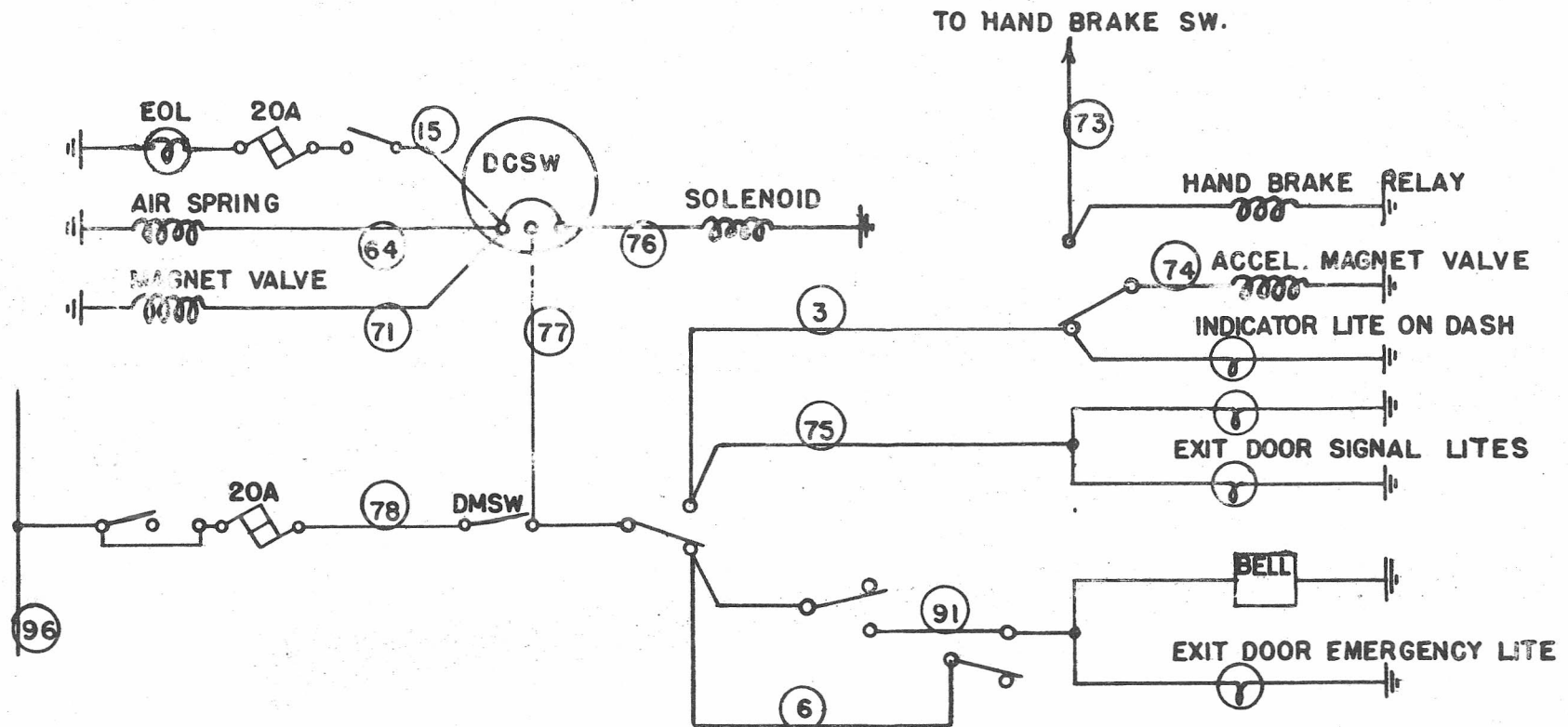

EOL ENTRANCE OVERHEAD LITE

DCSW DOOR CONTROL SWITCH

DMSW DOOR MASTER SWITCH

### DOOR CONTROL CIRCUITS

8200-8349

CHICAGO TRANSIT AUTHORITY  
 GENERAL SUPERINTENDENT OF ENGINEERING  
 EQUIPMENT ENGINEER'S OFFICE

SK-E-82558-C

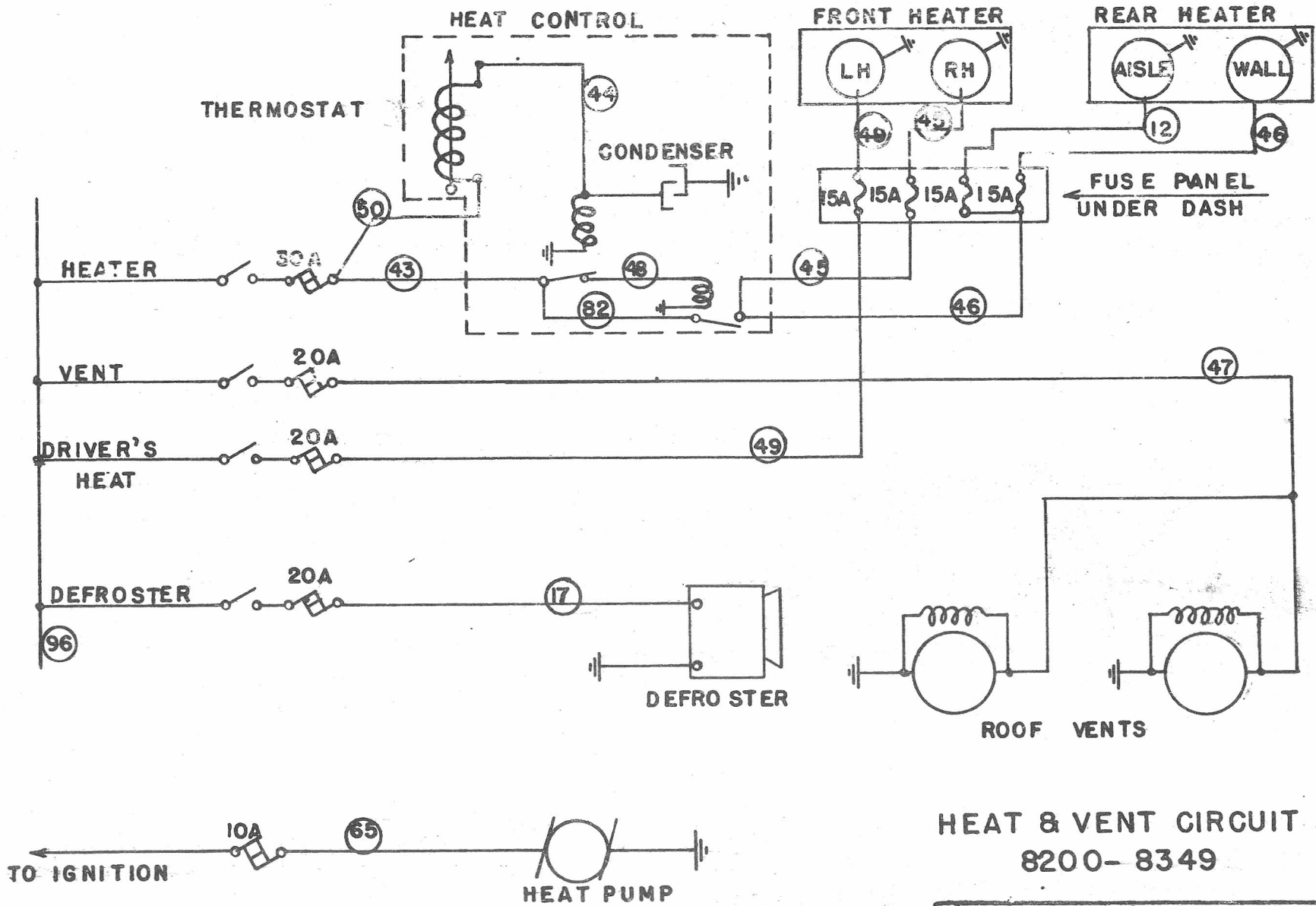

**HEAT & VENT CIRCUIT  
8200- 8349**

CHICAGO TRANSIT AUTHORITY  
GENERAL SUPERINTENDENT OF ENGINEERING  
EQUIPMENT ENGINEER'S OFFICE

REV. 10-31-58

SK-E-82558-D

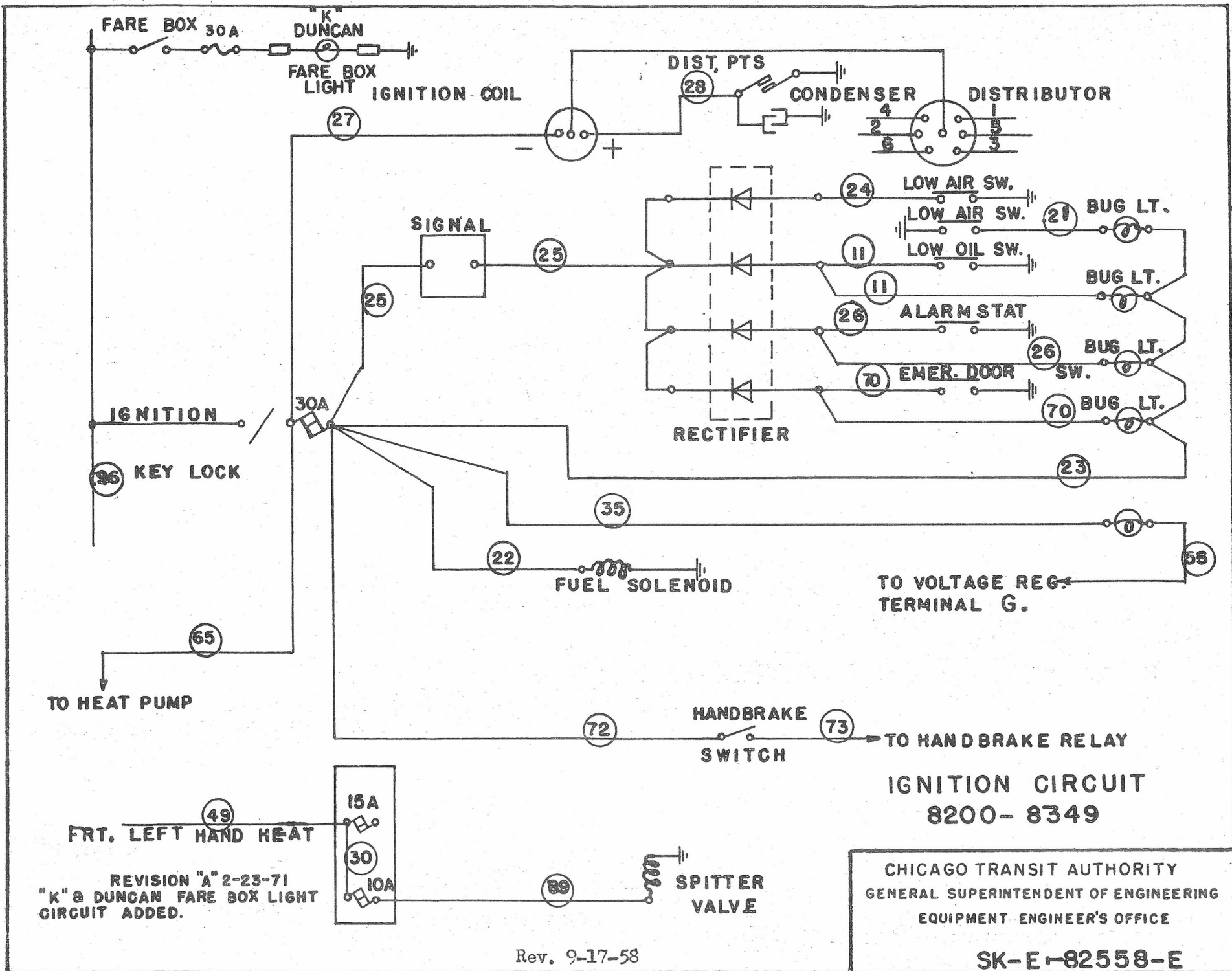

REVISION "A" 2-23-71  
 "K" & DUNCAN FARE BOX LIGHT  
 CIRCUIT ADDED.

**IGNITION CIRCUIT**  
**8200- 8349**

CHICAGO TRANSIT AUTHORITY  
 GENERAL SUPERINTENDENT OF ENGINEERING  
 EQUIPMENT ENGINEER'S OFFICE

Rev. 9-17-58

**SK-E-82558-E**

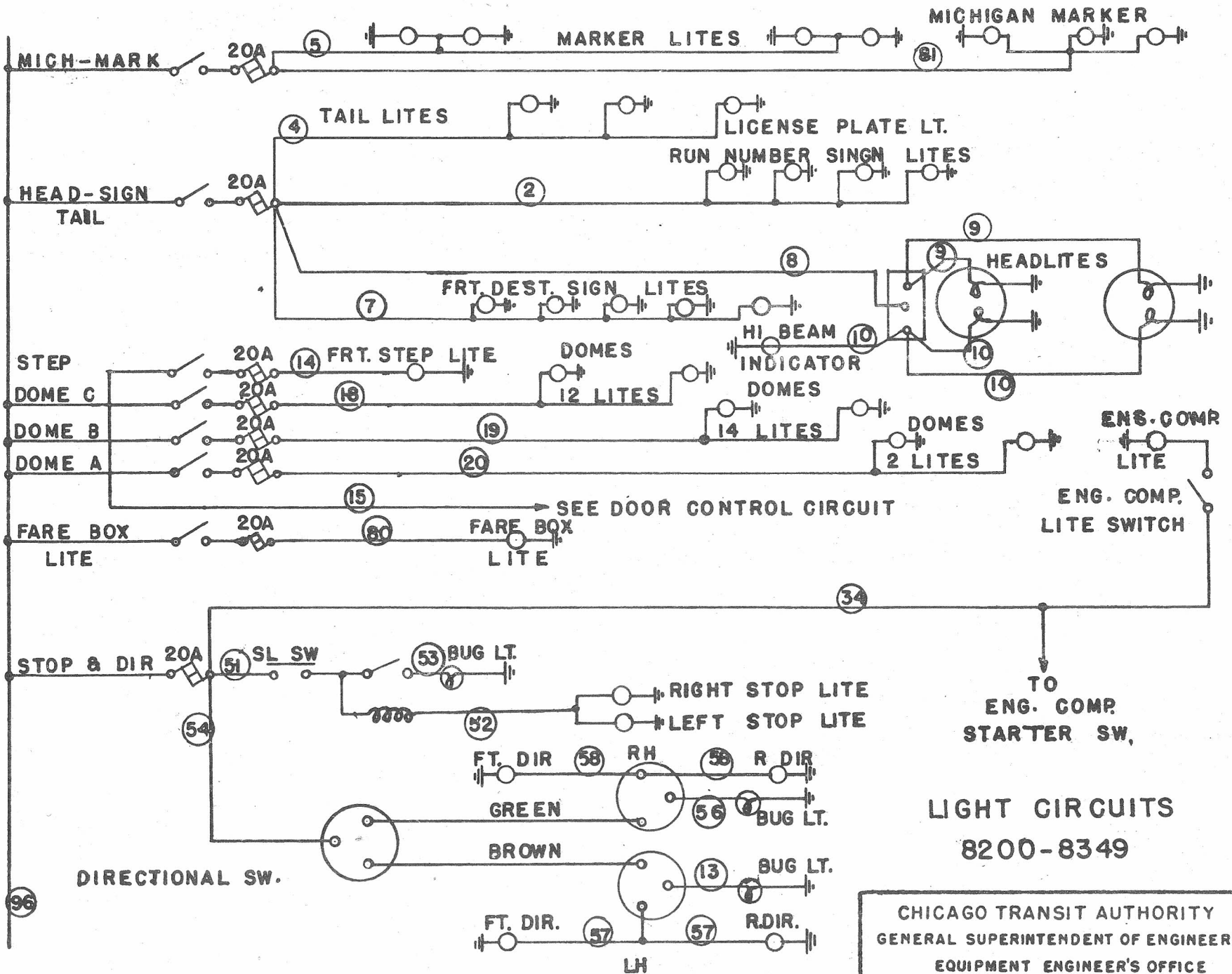

**LIGHT CIRCUITS  
8200-8349**

CHICAGO TRANSIT AUTHORITY  
GENERAL SUPERINTENDENT OF ENGINEERING  
EQUIPMENT ENGINEER'S OFFICE

**SK-E-82558-F**



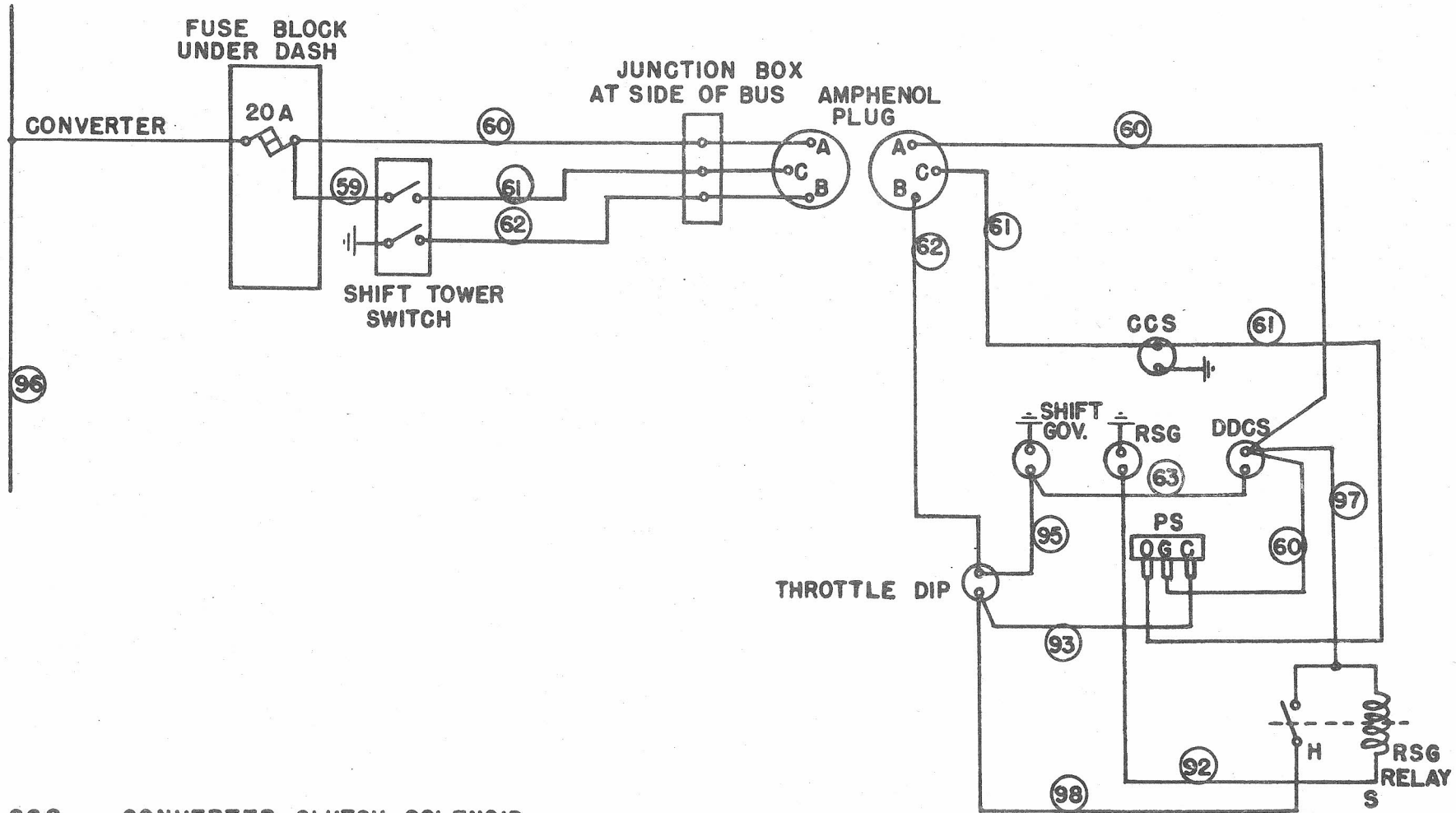

CCS      CONVERTER CLUTCH SOLENOID  
 DDGS    DIRECT DRIVE CLUTCH SOLENOID  
 GOV      GOVERNOR  
 PS       PRESSURE SWITCH  
 RSG      ROAD SPEED GOVERNOR

**THROTTLE DIP CIRCUIT**  
**8200-8349**

CHICAGO TRANSIT AUTHORITY  
 GENERAL SUPERINTENDENT OF ENGINEERING  
 EQUIPMENT ENGINEER'S OFFICE

REDRAWN 12-22-58

SK. E - 82558-G

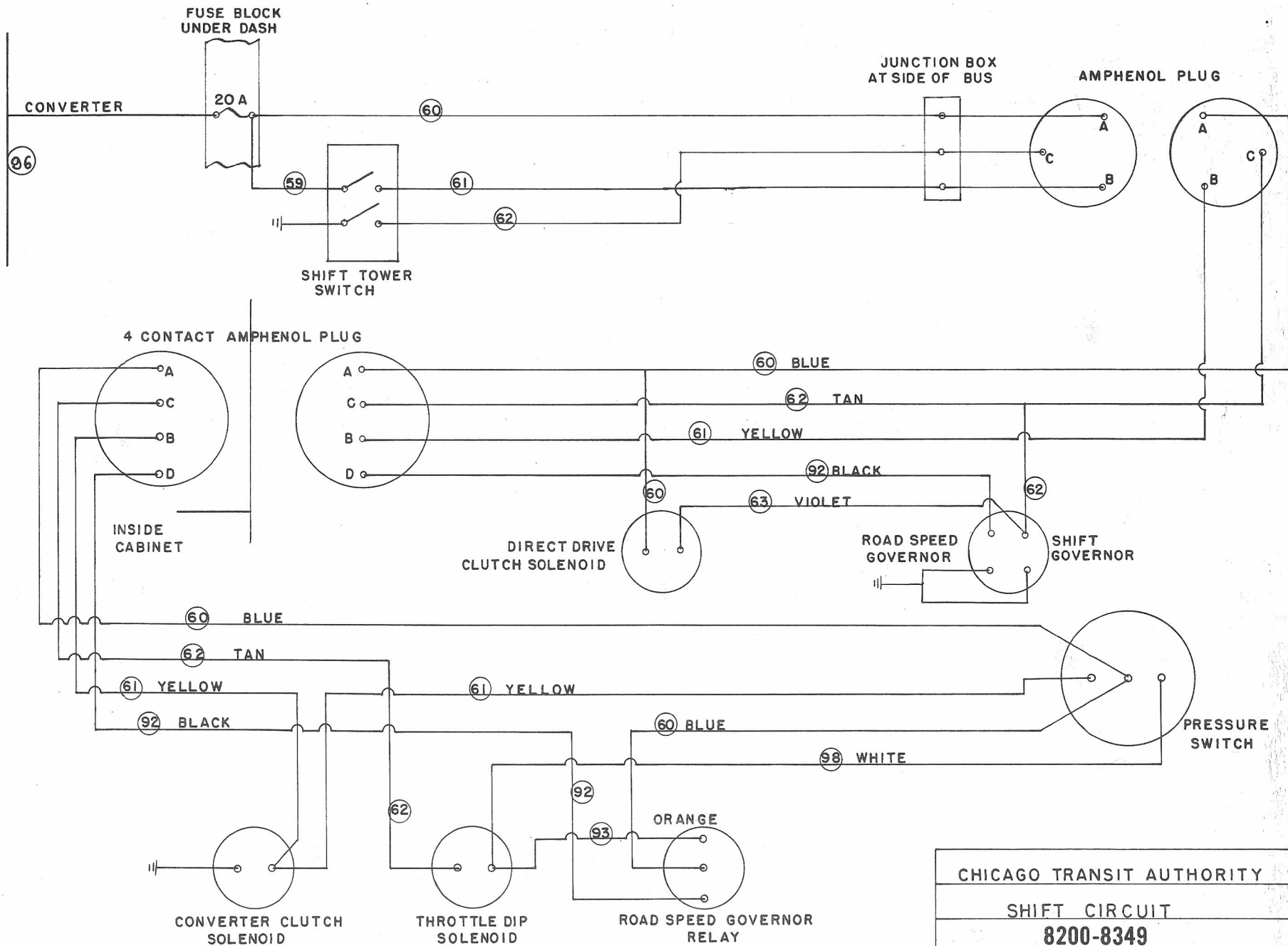

REVISED 11-8-63

RETAIN PAGE 7 (THROTTLE DIP CIRCUIT-SK-E-82558-G)  
UNTIL CAMPAIGN C-17-019 IS COMPLETED.

REVISED 12-5-63

REVISED 11-8-63

REVISED 9-17-63

CHICAGO TRANSIT AUTHORITY

SHIFT CIRCUIT

8200-8349

GENERAL SUPERINTENDENT OF ENGINEERING

OFFICE OF ENGINEER OF EQUIPMENT

SK-E-82558-H

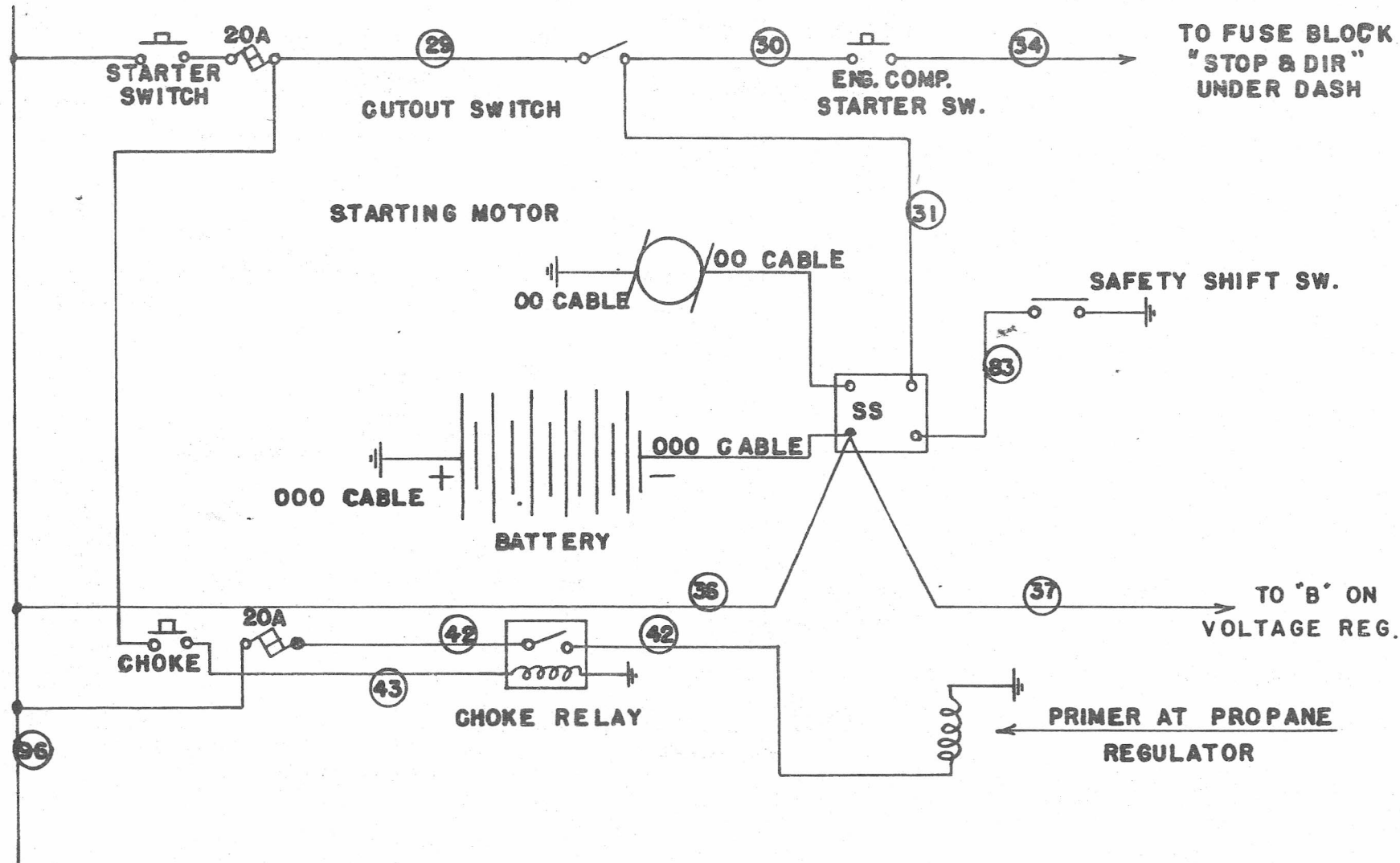

SS STARTER SOLENOID

**STARTING CIRCUIT  
8200-8349**

CHICAGO TRANSIT AUTHORITY  
GENERAL SUPERINTENDENT OF ENGINEERING  
EQUIPMENT ENGINEER'S OFFICE

**OBSOLETE**  
SEE DRAWING SK-E-120359-B

**SK-E-82558-1**

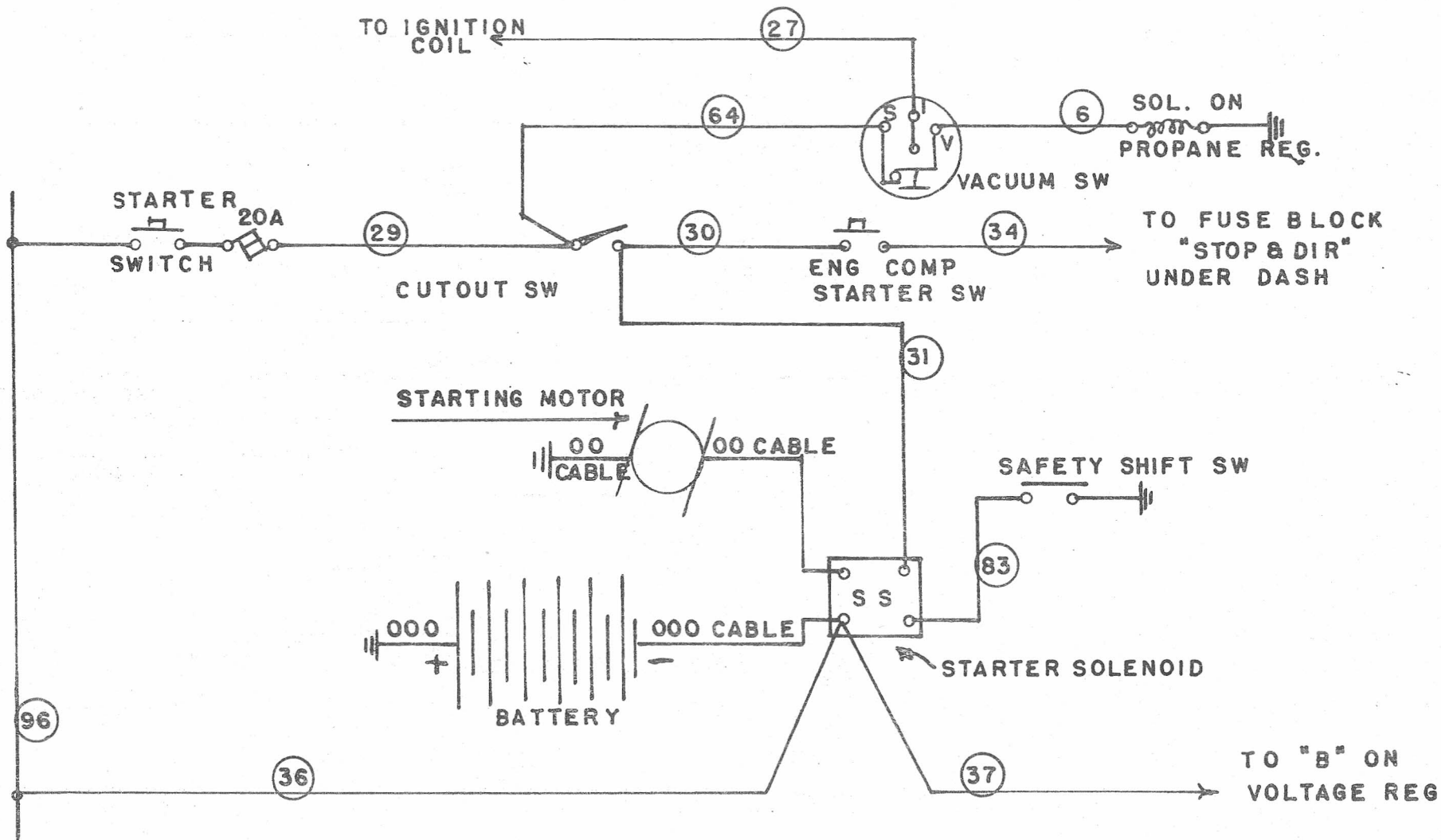

REVISION "A" 7-13-70  
8200-8349 SERIES ADDED

### STARTING CIRCUIT

8200-8349, 8400-8498

THIS DRG. OBSOLETES DRG. SK-E-82558-1

CHICAGO TRANSIT AUTHORITY  
GENERAL SUPERINTENDENT OF ENGINEERING  
EQUIPMENT ENGINEER'S OFFICE

SK-E-120359-B

LAMP DATA	
LOCATION	LAMP NO.
DESTINATION SIGN	94
DIRECTIONAL SIGNAL	1141
DOMES	93 L
ENGINE COMPARTMENT	89
EXIT DOOR SIGNAL	89
FARE BOX	94 IF
FRONT STEP	94 IF
INDICATOR LIGHTS	57
HEADLIGHTS	4430
LICENSE PLATE	89
MARKER-FRONT	68
MARKER-REAR	67
MICHIGAN MARKER	67
RUN NUMBER SIGN	68
STOP LITE	1016
TAIL LITE	1016
WARNING LITE-EXIT	67

8200-8349

CHICAGO TRANSIT AUTHORITY  
GENERAL SUPERINTENDENT OF ENGINEERING  
EQUIPMENT ENGINEER'S OFFICE

SK-E-82558-J

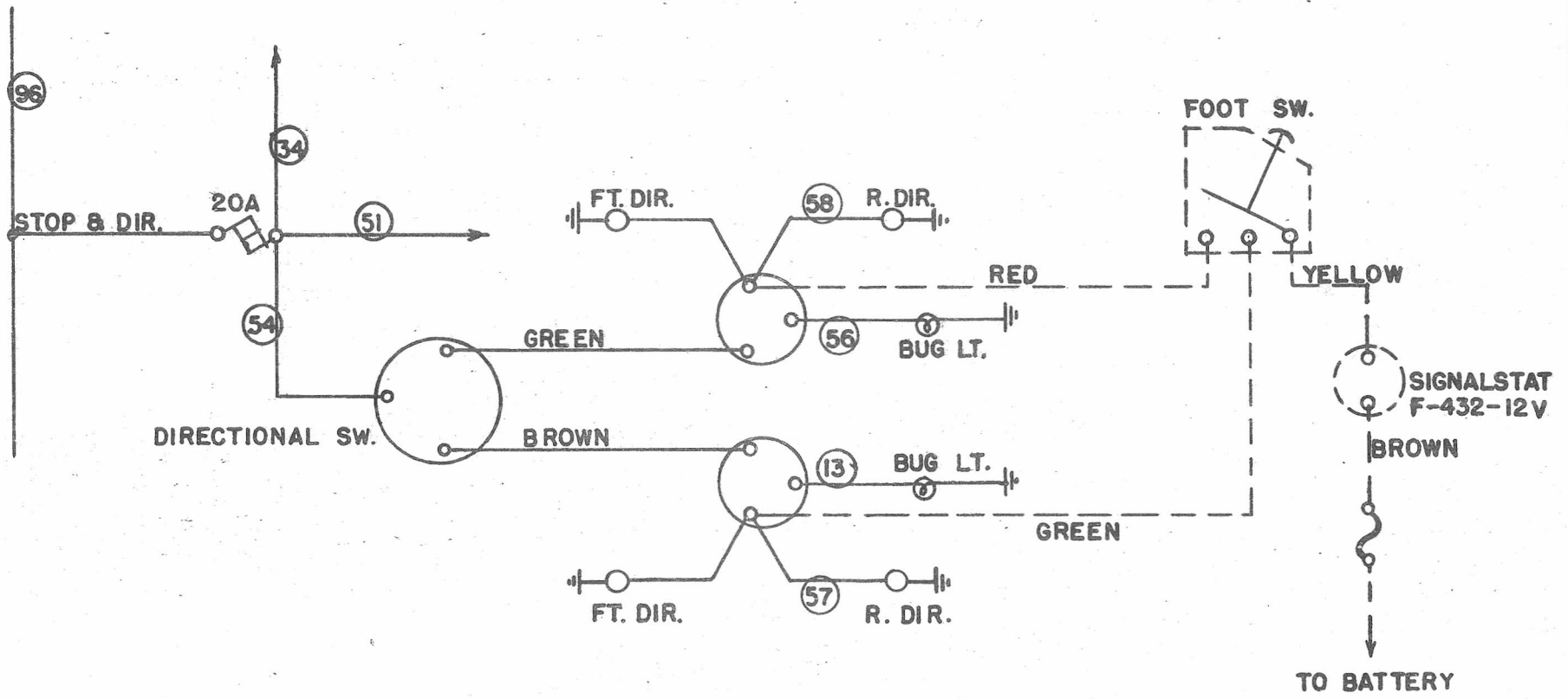

NOTE: DOTTED LINES REPRESENT PROPOSED CIRCUIT FOR EMERGENCY OPERATION OF ALL FOUR INDICATOR LITES.

CHICAGO TRANSIT AUTHORITY  
 GENERAL SUPERINTENDENT OF ENGINEERING  
 EQUIPMENT ENGINEER'S OFFICE  
 SK- E- 82558- SPC.

